



Labels and Branding

There are a variety of standard labels and branding that can be added to a garment.

**Bridge
& Stitch**

CONNECTING BRITISH APPAREL
DESIGN & MANUFACTURE

Label Types/Folds

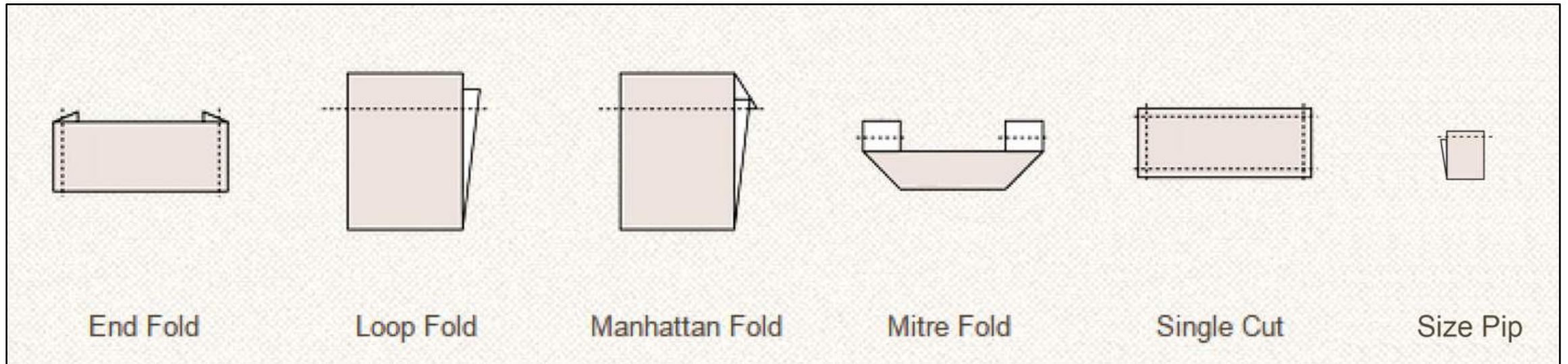

Label Qualities- Woven

A popular quality, woven labels are very durable, have better washability (than printed labels), and feel soft against the skin. Woven labels can be provided in damask, satin, and cotton qualities.



Damask Woven Labels

Most commonly used, these polyester labels have a high quality weave with a matte finish and a soft feel.

MOQ: 1000pcs per design, if the garment size is included on the label this can be broken down into 500pcs per size

Set-up Fees: Applicable



Satin Woven Labels

Soft, lustrous polyester thread is used to give a subtle sheen.

MOQ: 1000pcs per design, if the garment size is included on the label this can be broken down into 500pcs per size

Set-up Fees: Applicable



Cotton Woven Labels

Commonly used for childrenswear as the soft cotton threads do not irritate the skin.

MOQ: 1000pcs per design, if the garment size is included on the label this can be broken down into 500pcs per size

Set-up Fees: Applicable

Label Qualities- Printed

Functional and cost effective, printed labels are commonly used for care information and composition details. Printed labels can be produced in satin or cotton qualities.



Satin Printed Labels

Most common quality used for care labels (including our stock care labels), these have a soft feel and lustrous sheen.

MOQ: 1000pcs per design, if the garment size is included on the label this can be broken down into 500pcs per size

Set-up Fees: Applicable



Cotton Printed Labels

Ideal for labelling and supporting products that boast natural qualities.

MOQ: 1000pcs per design, if the garment size is included on the label this can be broken down into 500pcs per size

Set-up Fees: Applicable

Commonly Used Labels



Brand Label

These can be either printed or woven qualities, and are normally found in either the back neck or waistband of a garment. Sizes can also be included on the brand label, which reduces the minimum order to 500 pieces per size.

MOQ: 1000pcs per design, if the garment size is included on the label this can be broken down into 500pcs per size

Set-up Fees: Applicable

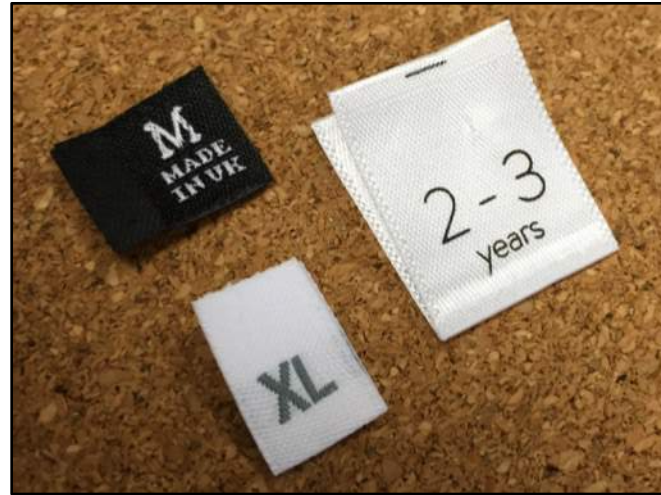

Size Pip

Another term for size labels. The garment size can also be included on care and brand labels, so these are optional, and can be fully custom depending on the clients requirements.

MOQ: 1000pcs per design, if the garment size is included on the label this can be broken down into 500pcs per size

Set-up Fees: Applicable

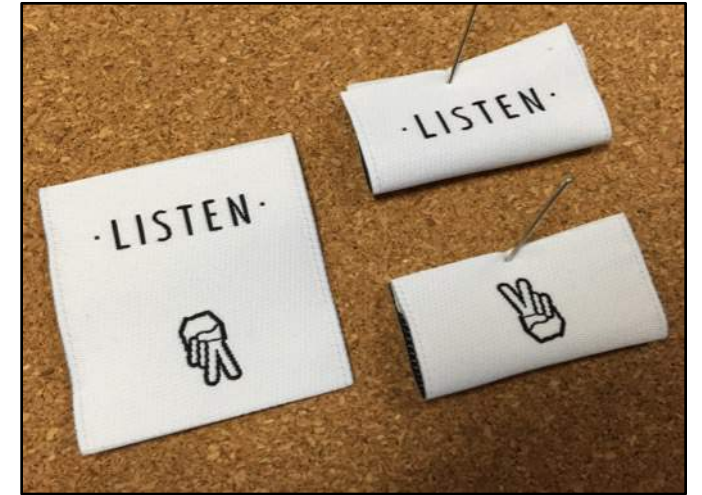

Hem Label

A Manhattan fold label which is wrapped around the hem and stitched to the outside of the garment, and can be commonly found on t-shirts.

MOQ: 1000pcs per design, if the garment size is included on the label this can be broken down into 500pcs per size

Set-up Fees: Applicable

Commonly Used Labels Cont'd



Stock Care Labels



Custom Care Labels

Care Labels

A legal requirement, care labels provide washing instructions and the fabric composition for each garment. These are usually found in the side seam.

We offer a selection of stock care labels for fabrics with common compositions, e.g. 100% Cotton or 100% Polyester. These are printed satin loop fold labels which have no minimum order (if in stock).

We can also supply fully custom care labels to your specification, or can amend our stock care label to a specific composition. Minimums are 1000 pieces per design.

MOQ: 1000 pcs per design for non-stock, custom, or amended labels

Set-up Fees: Applicable

Other Branding



Leather/PU Labels and Patches

Real or imitation leather labelling can be used for traditional jeans patches to garment and accessory branding, and can be produced to a clients own specification.

MOQ: 1000 pcs per design

Set-up Fees: Applicable



Swing Tickets

An information tag which is attached to a finished garment by either string or a plastic kimble. These usually have the brand logo and website details on them, but are fully custom including the size, shape and material, depending on the clients requirements.

MOQ: 1000 pcs per design

Set-up Fees: Applicable



Custom Elastic

Commonly used on sportswear, custom elastic can be in plush, knitted, or woven qualities and can be produced to a clients specification.

MOQ: 1000m per design

Set-up Fees: Applicable

Other Branding Cont'd



Custom/Branded Tapes

Commonly used as back neck tape of hanging loops, custom tapes can be either printed or woven qualities.

MOQ: Dependent on type
Set-up Fees: Dependent on tape quality



Branded Buttons

Buttons can be fully custom to a client's specification, and can come in a large variety of materials including wood, metal and polyester.

MOQ: 3000 pcs per design
Set-up Fees: Applicable



Silicone/Rubber Tabs

Made from PVC or silicone, rubber tabs are extremely durable and are commonly found on outerwear garments.

MOQ: 1000 pcs per design
Set-up Fees: Applicable



Metal Components

Metal fittings for both fashion and function, including jeans buttons, rivets, snap fasteners, eyelets and decals. Stock options can be provided in addition to custom made items in a vast array of styles and finishes.

MOQ: Dependent on item
Set-up Fees: Applicable